

## Robust, heavy-duty case proximity switches for DC operation

- Shielded and unshielded models
- IP67 nickel-plated brass housing
- Short-circuit protection
- Inductive loads protection
- Reverse polarity protection
- Side-mounted LED operation indicator
- Integral metal cable support or M12 metal plug
- Nominal sensing range shielded 10mm
- Unshielded 15mm

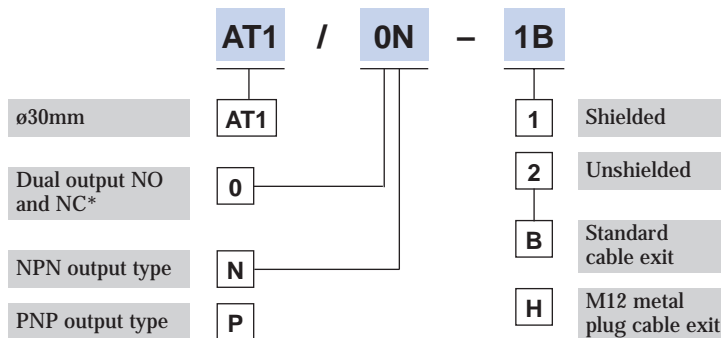

## Options and ordering codes



## Output circuit-wiring connections

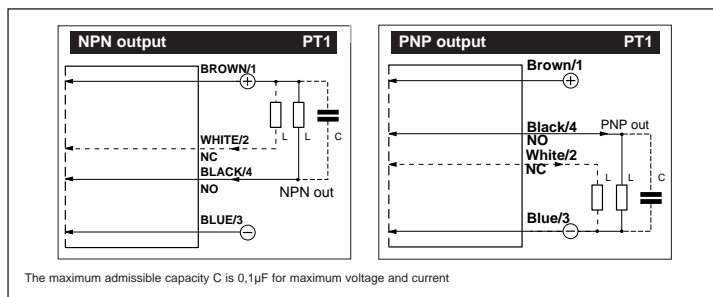

Normally closed output types

**Other cable options:**

Customised cables

Please contact IMO for price and availability

## Plug-pin connections

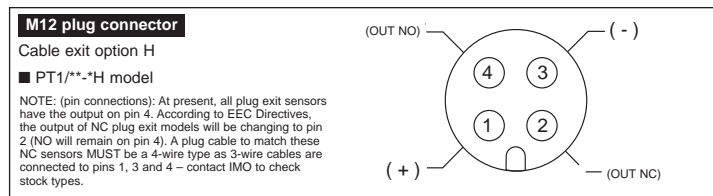

Please see – Full specification page 321

Mounting brackets page 330

Connector leads page 332

## Dimensions (mm)

